

CoroTurn® Prime and PrimeTurning™

Introducing a completely new turning concept, including method and tools, unlike anything ever seen before.



The biggest innovation in turning...since turning

PrimeTurning™ is a new methodology which enables you to do turning in all directions in much more efficient and productive way as compared to conventional turning. This concept comprises a new turning method, dedicated CoroTurn® Prime tools, and a code generator.

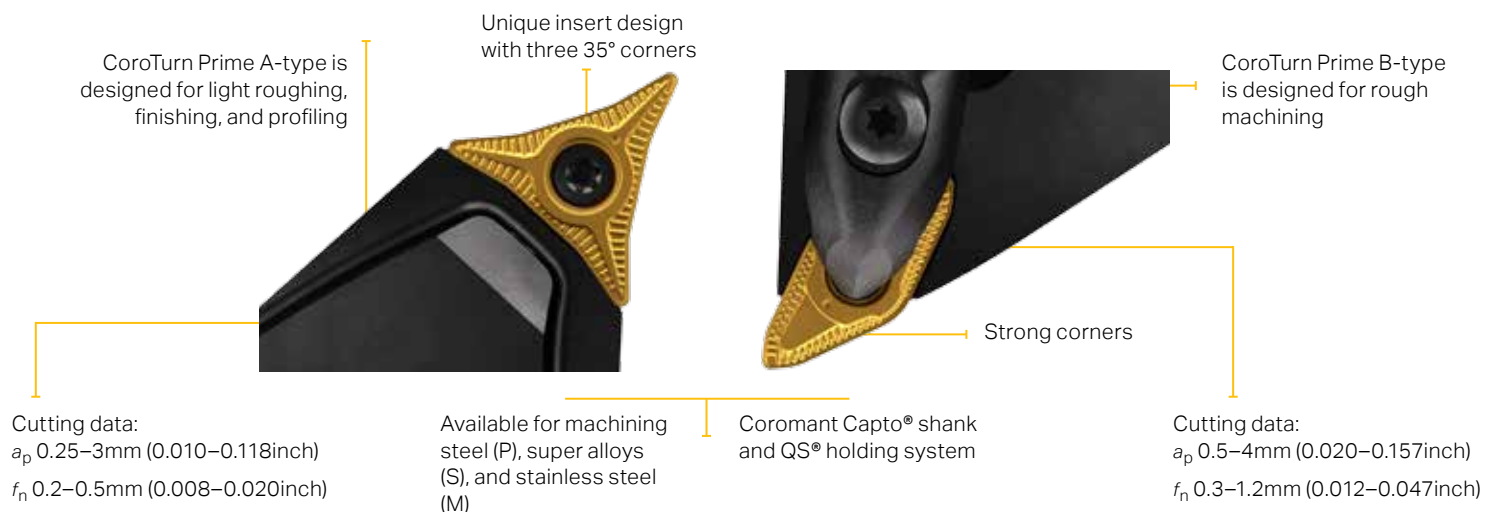

Secure maximum output with PrimeTurning code generator that supplies programming codes and techniques to set up proper parameters and variables for a particular application.

Success factors

The key attributes of PrimeTurning that result in increased productivity and long lasting tool life are:

Small entering angle

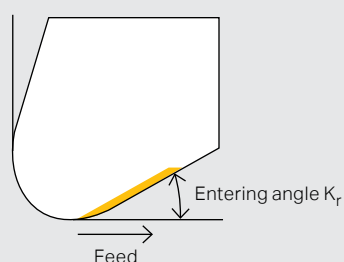

Efficient edge utilization

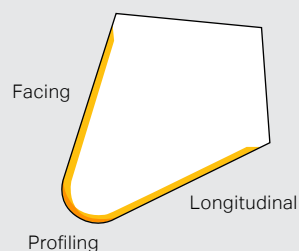

No chip jamming

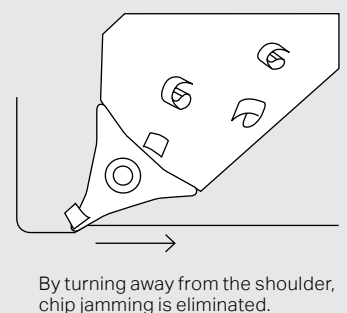

Why should you switch to PrimeTurning™ and CoroTurn® Prime?



New concept, tools, and code generator offer a more than 50% productivity increase as compared to conventional turning.

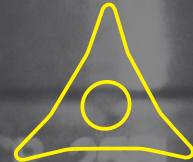

Longer lasting inserts as a result of the small entering angle and efficient edge utilization.

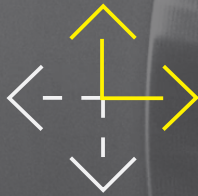

Flexibility to do turning in all directions for extraordinary productivity.



Increased profitability through lower capital expenses and reduced cost per component.



Higher machine utilization as a result of less set-up time, fewer production stops, and tool changes.



Doubled speed and feed rates enable faster metal removal for more parts per run.

Productivity gains with PrimeTurning™ and CoroTurn® Prime

CoroTurn® Prime A-type

Material	Cast, SAE 1045, CMC 02.1, 207 HB	
Coolant	Emulsion	
	Competitor insert	CoroTurn Prime A-type (CP-A1108-L5 4325)
v_c m/min (ft/min)	300 (984)	300 (984)
f_n mm/r (inch/r)	0.25 (.010)	0.4 (.016)
a_p mm (inch)	1.5 (.059)	3 (.118)
Results		
Total cycle time	70 sec	44 sec
Total life/edge	360 pcs	558 pcs



+59%
Productivity

CoroTurn® Prime B-type

Material	Forged, ASTM B564, CMC 20.21, 250 HB	
Coolant	Emulsion	
	Competitor insert	CoroTurn Prime B-type (CP-B1108-M5 2025)
v_c m/min (ft/min)	150 (492)	150 (492)
f_n mm/r (inch/r)	0.3 (.012)	0.8 (.032)
a_p mm (inch)	2 (.079)	4 (.156)
Results		
Total cycle time	2.43 min	1.36 min
Total life/edge	4 pcs	9 pcs



+85%
Productivity

Seeing is believing. Visit our website to see PrimeTurning in action:
www.sandvik.coromant.com/primeturning

Head office:
AB Sandvik Coromant
SE-811 81 Sandviken, Sweden
E-mail: info.coromant@sandvik.com
www.sandvik.coromant.com

C-1040:191 en-US © AB Sandvik Coromant 2017

SANDVIK
Coromant